

D7184D

QUAD-BAND Tx/ DUAL Rx SWITCH FRONT END MODULE
for GSM/GPRS (824-915MHz and 1710-1910MHz)

PRELIMINARY DATA SHEET

Version 0.2

Features

- Ultra-Small 6mm×6mm Package Size
- Low Profile
- Complete Power Control Solution
- No External Components or Routing

Typical Applications

- 3V GPRS/GSM Handsets
- Commercial and Consumer Systems
- Portable Battery-Powered Equipments

Product Description

The D7184D is a high-power , high-efficiency quad-band Tx/dual Rx Switch front end module. The module is a self-contained 6mm×6mm module with 50Ω input and output terminals. The module consists of quad-band power amplifiers and dual Rx antenna switch. The module is designed for use as the final portion of the transmitter section in a GSM/GPRS cell phone and other applications in the 824MHz to 849MHz , 880MHz to 915MHz, 1710MHz to 1785MHz , 1850MHz to 1910MHz bands and eliminates the need for antenna switch and matching network. The D7184D requires no external routing or external components, simplifying layout and reducing board space.

Optimum Process Technology Applied

- √GaAs HBT
- √GaAs pHEMT
- √Si CMOS

Functional Block Diagram

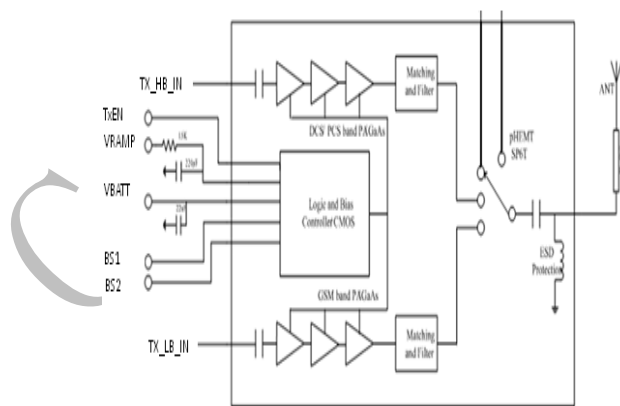

Pin Assignment

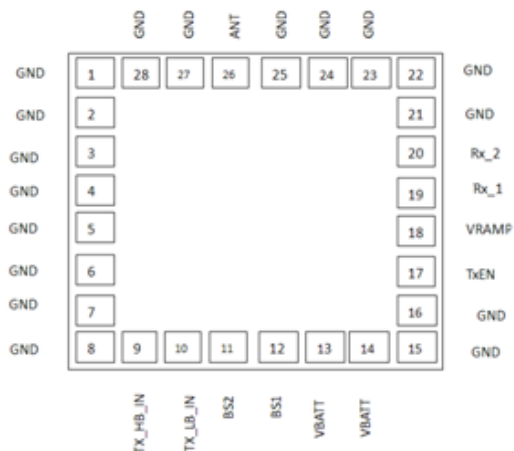

Table 1: Pin Description

Pin No	Definition	Description
9	TX_HB_IN	High band RF input,1710-1910MHz,50Ω input
10	TX_LB_IN	Low band RF input,824-915MHz,50Ω input
11	BS2	Band select
12	BS1	Band select
13,14	VBATT	Battery input voltage , 3.2-4.5V,Trace should be as wide as possible.
17	TxEN	Tx/Rx mode control. Enables the PA module for Tx mode with a logic high.
18	VRAMP	Analog power control voltage input, A RC filter outside is preferred.
19, 20	Rx	Rx (1-2) 824MHz to 2170MHz ,50Ω output
26	ANT	RF IN/OUT to Antenna,50Ω
1-8,15-16,21-25,27,28	GND	RF and DC Ground
GROUND GRID		GND PAD, must be connected to main GND

Table2: Control Logic Tables

Control Logic	TxEN	BS1	BS2
Power Down(Standby)	0	0	0
LB_Tx	1	0	1
HB_Tx	1	1	1
Rx_1	0	1	1
Rx_2	0	0	1

Table 3: Absolute Maximum Ratings

PARAMETER	MIN	MAX	UNIT
Supply Voltage	-0.3	+5.0	V
Power Control Voltage (VRAMP)	-0.3	+1.65	V
RF Input Power		+10	dBm
Max Duty Cycle		50	%
Output Load VSWR		20:1	
Operating Case Temperature	-20	+85	°C
Storage Temperature	-55	+150	°C

Table 4: Electrical Characteristics

Parameter	Specification			Unit	Condition
	Min.	Typ.	Max.		
Overall Power Control VRAMP					
Power Control "ON"			1.65	V	
Power Control "OFF"		0.27		V	
VRAMP Input Capacitance		2	20	pF	DC to 2MHz
VRAMP Input Current			30	μA	VRAMP=1.65V
Power Control Range		50		dB	VRAMP=0.27V to 1.65V
Overall Power Supply					
Power Supply Voltage		3.5		V	Specifications
	3.2		4.5	V	Nominal operating limits
Power Supply Current		1		μA	PIN<-30dBm, TxEN =Low, Temp=-20°C to +85°C
			15	mA	VRAMP=0.27V, TxEN =High
Overall Control Signals					
BS2/BS1 /MODE "Low"	0	0	0.5	V	
BS2/BS1 /MODE "High"	1.6	2.0	3.0	V	
BS2/BS1 /MODE "High" Current		10	20	μA	
TxEN "Low"	0	0	0.5	V	
TxEN "High"	1.6	2.0	3.0	V	
TxEN "High" Current		10	20	μA	

Table 5: Electrical Specification for GSM850 Tx

PARAMETER	SPECIFICATION			UNIT	CONDITION
	MIN	TYP	MAX		
Overall					Temp=+25°C,VBATT=3.5V, VRAMP =1.65V, TX_LB_IN=3dBm, Freq=824MHz to 849MHz, 25%Duty Cycle, Pulse Width=1154us
Operating Frequency Range	824		849	MHz	
Maximum Output Power 1		33.2		dBm	Temp=+25°C , VBATT=3.5V, VRAMP =1.65V
Maximum Output Power 2	30.5			dBm	Temp=+85°C , VBATT=3.5V, VRAMP =1.65V
Total Efficiency		36		%	At P _{OUT MAX}
Input Power Range	0	+3	+6	dBm	
Output Noise Power			-82	dBm	RBW=100kHz, 869 MHz to 894MHz, P _{OUT} ≤+33dBm
			-74	dBm	RBW=100kHz, 1930 MHz to 1990MHz, P _{OUT} ≤+33dBm
Forward Isolation 1		-60	-40	dBm	TxEN =Low, TX_LB_IN=+5dBm
Forward Isolation 2		-40	-15	dBm	TxEN =High, TX_LB_IN=+5dBm, VRAMP =0.27V
Second Harmonic		-40	-30	dBm	VRAMP =0.27V to 1.65V
Third Harmonic		-40	-35	dBm	VRAMP =0.27V to 1.65V
All other Non-Harmonic Spurious			-36	dBm	VRAMP =0.27V to 1.65V
Input Impedance		50		Ω	
Input VSWR			2.5:1		
Output Load VSWR stability (Spurious emission)			-36	dBm	VSWR=12:1
Output Load VSWR Ruggedness	No damage or permanent degradation				VSWR=20:1
Output Load impedance		50		Ω	Load impedance presented at RF OUT pad
Switch Leakage Pout at Rx Port GSM850,ANT-GSM850_Rx		3		dBm	LB_Tx Mode, Freq=824 to 849MHz Pout=33dBm at ANT Port.

Table 6: Electrical Specification for EGSM900 Tx

PARAMETER	SPECIFICATION			UNIT	CONDITION
	MIN	TYP	MAX		
Overall					Temp=+25°C,VBATT=3.5V, VRAMP =1.65V, TX_LB_IN=3dBm, Freq=880MHz to 915MHz, 25%Duty Cycle, Pulse Width=1154us
Operating Frequency Range	880		915	MHz	
Maximum Output Power 1		33.2		dBm	Temp=+25°C, VBATT=3.5V, VRAMP =1.65V
Maximum Output Power 2	30.5			dBm	Temp=+85°C, VBATT=3.5V, VRAMP =1.65V
Total Efficiency		36		%	At P _{OUT} MAX
Input Power Range	0	+3	+6	dBm	
Output Noise Power			-77	dBm	RBW=100kHz, 925 MHz to 935MHz, P _{OUT} ≤ +33dBm
			-80	dBm	RBW=100kHz, 935 MHz to 960MHz, P _{OUT} ≤ +33dBm
			-84	dBm	RBW=100kHz, 1805 MHz to 1880MHz, P _{OUT} ≤ +33dBm
Forward Isolation 1		-60	-40	dBm	TxEN =Low, TX_LB_IN=+5dBm
Forward Isolation 2		-40	-15	dBm	TxEN =High, TX_LB_IN=+5dBm, VRAMP =0.27V
Second Harmonic		-40	-30	dBm	VRAMP =0.27V to 1.65V
Third Harmonic		-40	-35	dBm	VRAMP =0.27V to 1.65V
All other Non-Harmonic Spurious			-36	dBm	VRAMP =0.27V to 1.65V
Input Impedance		50		Ω	
Input VSWR			2.5:1		
Output Load VSWR stability (Spurious emission)			-36	dBm	VSWR=12:1
Output Load VSWR Ruggedness	No damage or permanent degradation				VSWR=20:1
Output Load impedance		50		Ω	Load impedance presented at RF OUT pad
Switch Leakage Pout at Rx Port EGSM900,ANT-EGSM900_Rx		3		dBm	LB_Tx Mode, Freq=880 to 915MHz Pout=33dBm at ANT Port.

Table 7: Electrical Specification for DCS Tx

PARAMETER	SPECIFICATION			UNIT	CONDITION
	MIN	TYP	MAX		
Overall					Temp=+25°C,VBATT=3.5V, VRAMP =1.65V,TX_HB_IN=3dBm, Freq=1710MHz to1785MHz, 25%Duty Cycle, Pulse Width=1154us
Operating Frequency Range	1710		1785	MHz	
Maximum Output Power 1		30.5		dBm	Temp=+25°C,VBATT=3.5V, VRAMP =1.65V
Maximum Output Power 2	28.0			dBm	Temp=+85°C,VBATT=3.0V, VRAMP =1.65V
Total Efficiency		35		%	At P _{OUT MAX}
Input Power Range	0	+3	+6	dBm	
Output Noise Power		-85	-77	dBm	RBW=100kHz, 925MHz to 935MHz, P _{OUT} ≤ +30dBm
			-83	dBm	RBW=100kHz, 935 MHz to 960MHz, P _{OUT} ≤ +30dBm
			-79	dBm	RBW=100kHz,1805 MHz to 1880MHz, P _{OUT} ≤ +30dBm
Forward Isolation 1		-60	-53	dBm	TxEN =Low, TX_HB_IN=+5dBm
Forward Isolation 2		-45	-15	dBm	TxEN =High, TX_HB_IN=+5dBm, VRAMP =0.27V
Second Harmonic		-40	-33	dBm	VRAMP =0.27V to 1.65V
Third Harmonic		-40	-35	dBm	VRAMP =0.27V to 1.65V
All other Non-Harmonic Spurious			-36	dBm	VRAMP =0.27V to 1.65V
Input Impedance		50		Ω	
Input VSWR			2.5:1		
Output Load VSWR Stability (Spurious emission)			-36	dBm	VSWR=12:1
Output Load VSWR Ruggedness	No damage or permanent degradation				VSWR=20:1
Output Load impedance		50		Ω	Load impedance presented at RF OUT pad
Switch Leakage Pout at Rx Port DCS1800,ANT-DCS_Rx		5		dBm	HB_Tx Mode, Freq=1710 to 1785MHz Pout=30dBm at ANT Port.

Table8: Electrical Specification for PCS Tx

PARAMETER	SPECIFICATION			UNIT	CONDITION
	MIN	TYP	MAX		
Overall					Temp=+25°C,VBATT=3.5V, VRAMP =1.65V,TX_HB_IN=3dBm, Freq=1850MHz to1910MHz, 25%Duty Cycle, Pulse Width=1154us
Operating Frequency Range	1850		1910	MHz	
Maximum Output Power 1		30.2		dBm	Temp=+25°C,VBATT=3.5V, VRAMP =1.65V
Maximum Output Power 2	28.0			dBm	Temp=+85°C,VBATT=3.0V, VRAMP =1.65V
Total Efficiency		33		%	At P _{OUT MAX}
Input Power Range	+1	+3	+6	dBm	
Output Noise Power		-85	-80	dBm	RBW=100kHz,869 MHz to 894MHz, P _{OUT} ≤ +30dBm
			-74	dBm	RBW=100kHz,1930 MHz to1990MHz, P _{OUT} ≤ +30dBm
Forward Isolation 1		-60	-53	dBm	TxEN =Low, TX_HB_IN=+5dBm
Forward Isolation 2		-45	-15	dBm	TxEN =High, TX_HB_IN=+5dBm, VRAMP =0.27V
Second Harmonic		-40	-33	dBm	VRAMP =0.27V to 1.65V
Third Harmonic		-40	-35	dBm	VRAMP =0.27V to 1.65V
All other Non-Harmonic Spurious			-36	dBm	VRAMP =0.27V to 1.65V
Input Impedance		50		Ω	
Input VSWR			2.5:1		
Output Load VSWR Stability (Spurious emission)			-36	dBm	VSWR=12:1
Output Load VSWR Ruggedness	No damage or permanent degradation				VSWR=20:1
Output Load impedance		50		Ω	Load impedance presented at RF OUT pad
Switch Leakage Pout at Rx Port PCS1900,ANT-PCS_Rx		5		dBm	HB_Tx Mode, Freq=1850 to 1910MHz Pout=30dBm at ANT Port.

Table 9: Electrical Specification for Rx

PARAMETER	SPECIFICATION			UNIT	CONDITION
	MIN	TYP	MAX		
Overall					Temp=+25°C,VBATT=3.5V, VRAMP =1.65V,TX_HB_IN=3dBm, TxEN =0, Rx Freq=824MHz to 960MHz Rx Freq=1710MHz to 2170MHz
Insertion Loss, ANT- Rx		1.0	1.2	dB	Rx Freq=824MHz to 960MHz
Insertion Loss, ANT- Rx		1.1	1.3	dB	Rx Freq=1710MHz to 2170MHz
Isolation from RX	20			dB	All Rx ports
IMD2 $f_{RX}-f_{TX}$		-103	-100	dBm	Tx Output Power = 20 dBm
IMD2 $f_{RX}+f_{TX}$		-103	-100	dBm	Blocker Power = -15 dBm
IMD3 $f_{RX}-f_{TX}$		-100	-97	dBm	Blocker freq. swept over all phase angles at Rx port
IMD3 $f_{RX}+f_{TX}$		-100	-97	dBm	
Harmonic 2f			-39	dBm	Tx Output Power = 26 dBm
Harmonic 3f			-39	dBm	
VSWR @ ANT		1.7:1	2:1		

Application Schematic

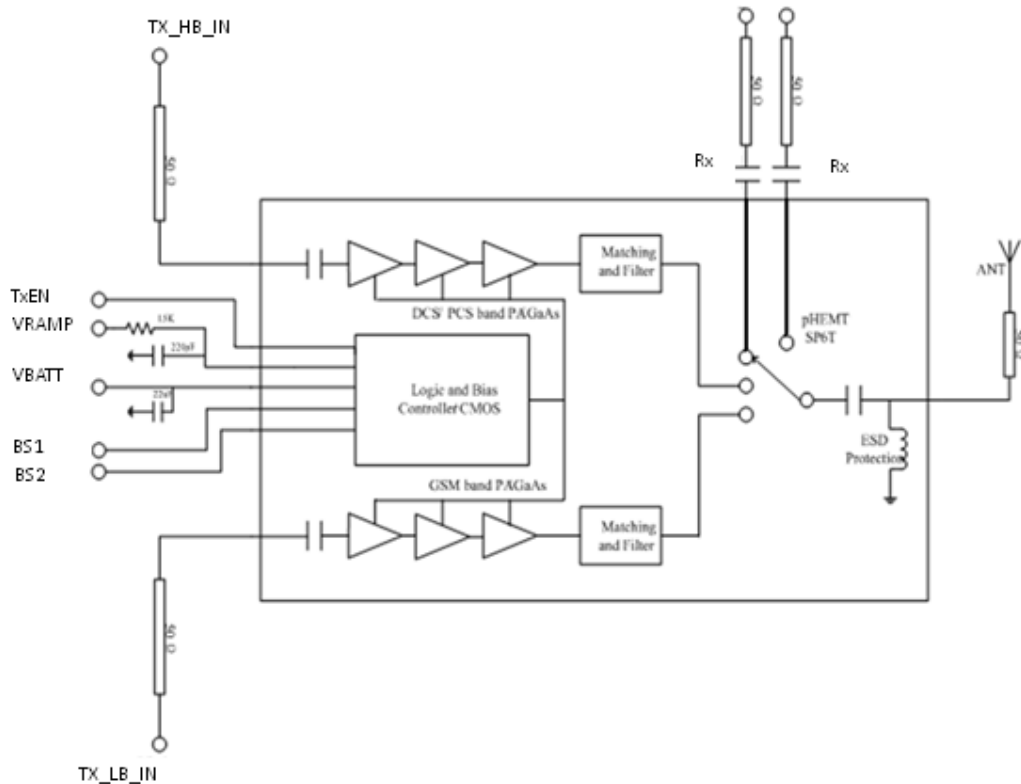

Please pay attention to the following notes before your new design.

- 1) A RC filter is preferred at VRAMP and a 22μF bypass capacitor at VBATT maybe changed on application.
- 2) RF ports are all 50Ω, including TX_HB_IN, TX_LB_IN, ALL Rx and Antenna port.
- 3) DC-blocking capacitors are necessary in all Rx ports, DC-blocking capacitors are inside in TX_HB_IN&TX_LB_IN ports, the ESD protector is inside in Antenna port.

ORDERING INFORMATION

ORDER NUMBER	TEMPERATURE RANGE	PACKAGE DESCRIPTION	COMPONENT PACKAGING
<u>D7184D</u>	-20°C to +85°C	6mm × 6mm × (1.0+/-0.1) mm LGA	Tape and Reel, <u>3000</u> per reel

Confidential - DAC

Disclaimer

Information in this document is provided in connection with DAC Semiconductor Corporation ("DACsemi") products. These materials are provided by DACsemi as a service to its customers and may be used for informational purposes only. DACsemi assumes no responsibility for errors or omissions in these materials. DACsemi may make changes to its products, specifications and product descriptions at any time, without notice. DACsemi makes no commitment to update the information and shall have no responsibility for conflicts, incompatibilities, or other difficulties arising from future changes to its products and product descriptions.

All of this information described herein should not be implied or granted for any third party. DACsemi does not authorize or warrant any DACsemi products for use in the life support devices or systems.

Contact Information

For technical questions and additional information about DAC Semiconductor Corporation:

DAC Semiconductor (Kunshan)

Tel: +86-512-5701-7979

Fax: +86-512-5701-7977

DAC Semiconductor (San Jose)

USA Tel: +1-408-435-7930

USA Fax: +1-408-435-7935

Confidential — DAC